

# DRACO K90 RS

## Data Sheet

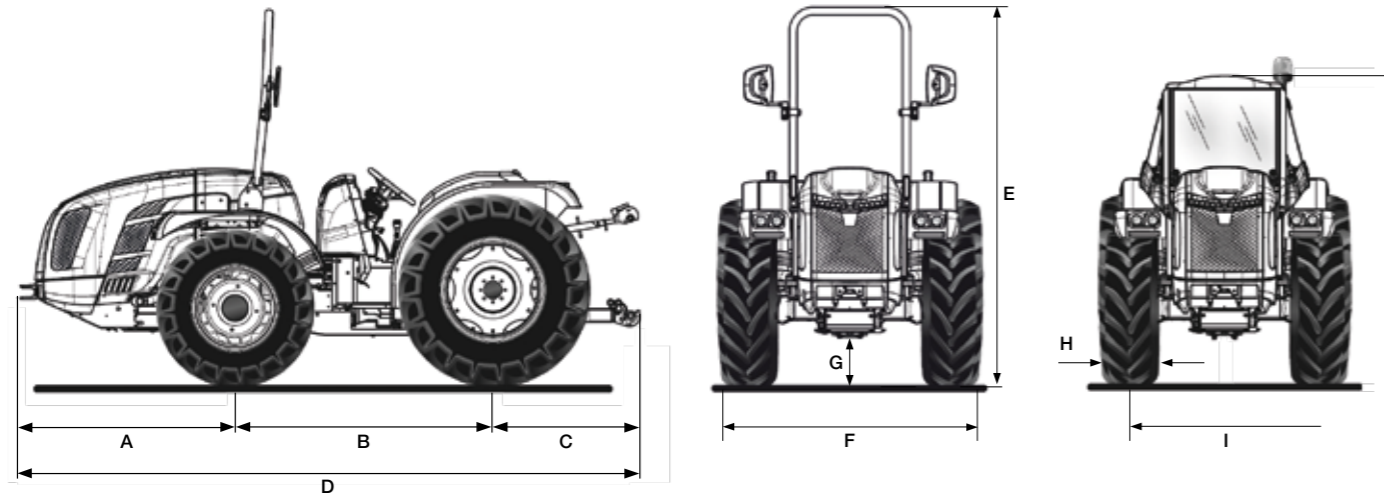

A	B	C	D	E min/max (with roll-bar)	E min/max (with cab)	G min/max
1348	1607	968	3923	2216 / 2316	1765 / 1865	157 / 257

\* Dimensions in mm

	260/70 R16	300/70 R20	260/70 R16	340/65 R20	280/70 R18	360/70 R20	280/70 R18	320/70 R24
	front	rear	front	rear	front	rear	front	rear
<b>H</b>	258	286	258	343	265	357	265	316
<b>I</b>	1122 / 1522	1054 / 1490	1122 / 1522	1054 / 1490	1098 / 1538	1170 / 1490	1098 / 1538	1034 / 1518
<b>F</b>	1380 / 1780	1340 / 1776	1380 / 1780	1397 / 1833	1363 / 1803	1527 / 1847	1363 / 1803	1350 / 1834

	320/65 R18	380/70 R20	340/65 R18	420/65 R24	320/65 R18	320/70 R24	280/70 R18	380/70 R20
	front	rear	front	rear	front	rear	front	rear
<b>H</b>	319	370	343	418	319	316	265	370
<b>I</b>	1166 / 1470	1170 / 1490	1166 / 1470	1190 / 1460	1166 / 1470	1034 / 1518	1098 / 1538	1170 / 1490
<b>F</b>	1485 / 1789	1540 / 1860	1509 / 1813	1608 / 1878	1485 / 1789	1350 / 1834	1363 / 1803	1540 / 1860

\* Dimensions in mm - min / max  
H = Tyre width - I = Wheel track - F = Tractor width

TECHNICAL FEATURES	DRACO K90 RS
<b>ENGINE</b>	Kubota V3800-CR-T-EW03   Diesel direct injection common rail   Turbo   4 cylinders   3769 cc   Liquid cooling   Stage V
Power	54.6 kW / 75 hp @2400 rpm   Max torque 305.4 Nm@1500 rpm
Speed management	Electronically regulated with a console with functions: increase and decrease of engine speed, memorize and recall a particular speed, switch off the electronic throttle and go to the minimum idle speed
<b>CHASSIS</b>	Swinging integral chassis (±15°) OS-FRAME with steering wheels
<b>DRIVE</b>	Four-wheel drive. Front-wheel drive disengagement with electro-hydraulic control
<b>TRANSMISSION</b>	32 speeds synchronized gearbox: 16 FWD and 16 REV with synchronized reverser
Min/max travel speed (km/h)	0.7 / 40
<b>POWER SHUTTLE EASYDRIVE® (optional)</b>	Electronically controlled electro-hydraulic with lever positioned to the left of the steering wheel and two available reversing modes: slow reverse and quick reverse
Transmission clutch	Multidisc in oil bath electronically-managed and proportional hydraulic control with PRO-ACT System
<b>DIFFERENTIAL</b>	Front and rear. Differential lock: front and rear simultaneously or only rear with electro-hydraulic control
<b>AXLES</b>	Front with planetary reduction units and rear with bull-gear units
<b>REAR PTO</b>	Independent from the gearbox and synchronized with forwarding speed. Negative safety hydraulic brake to stop the PTO
PTO clutch	Multidisc in oil bath with electro-hydraulic control
PTO rotation speed (rpm)	Standard: 540/540E - Optional: 540/1000
<b>HYDRAULIC SYSTEM</b>	Double circuit with independent pumps and heat exchanger
Hydraulic pump flow rate of the power steering and electro-hydraulic controls (l/min)	33.1
Hydraulic pump flow rate of the lift and control valves (l/min)	27.7 (optional oversized pump with flow rate 49 l/min)
Maximum hydraulic pressure (bar)	180
<b>REAR CONTROL VALVES</b>	Mechanical control, standard free flow oil return
Standard	2 double acting (total 5 hydraulic outlets)
Optional	Up to a maximum of 9 hydraulic outlets
Joystick (optional)	Proportional electronic control of rear lift (and front lift if present), 1 continuous flow with adjustable flow rate and free flow oil return, 3 double acting (replacing the standard ones). Potentiometer for adjusting the hydraulic flow rate and 49 l/min oversized pump
<b>REAR LIFT</b>	Standard: up/down lift with two external cylinders - Optional: position and draft-controlled
Three-point hitches	Standard: normal couplings cat. 1 and 2 - Optional: fixed arms with quick-couplings cat. 1 and 2 or Quick-couplings cat. 1 and 2, L-shaped, arms adjustable in length and hooks adjustable in width
Three-point tie bar	Standard: with manual adjustment - Optional: hydraulically controlled upper link and tie rod link arm
Ball joint lifting capacity (kg)	2700
<b>FRONT LIFT (optional)</b>	Two-cylinder, complete with front bumper and 4 front hydraulic outlets (replicated from the rear)
Three-point hitches	Rigid with quick couplings cat. 1
Lifting capacity (kg)	800
<b>DRIVING PLATFORM</b>	Monodirectional with platform suspended on silent-blocks. Suspended pedals mounted on control tower
Steering wheel	Tilt adjustable
Seat	With safety belt and 'man on board sensor'. Standard: comfortable sprung seat, adjustable according to the driver's weight - Optional: 'Grammer' pneumatic seat
<b>SERVICE BRAKES</b>	Oil bath discs with hydrostatic control, acting on the four wheels with automatic engagement of the 4-wheel drive. Independent manoeuvring brakes acting on the rear wheels
Parking brake	Standard: acting on the rear transmission, with lever control - Optional: automatic and independent Brake-Off acting as emergency brake with proportional action (standard with cab)
<b>STEERING</b>	Hydrostatic steering acting on the front wheels
<b>SAFETY</b>	Standard: front homologated roll-bar, with gas springs for an easy lowering and lifting
<b>CABIN (optional)</b>	"Compact Pro" low-profile, pressurised and homologated cat. 4 (activated carbon filters required). Soundproof, with monocoque body mounted on silent-blocks, beacon lamp and fabric seat. Safety cell integrated into the structure, automotive-type instrument dashboard and air vents. Air conditioning and Brake-Off parking brake as standard. Optional: activated carbon filters for cat. 4
<b>DASHBOARD</b>	Instrument panel with analogue gauges and TFT digital colour display. Warning lights and horn
<b>ELECTRIC SYSTEM</b>	Battery 100 Ah / 12 V - Alternator 95 A
Standard equipment	Vehicle Control Unit, full LED street lights and indicator system, front LED working lights, rear 7-pin and 3-pin sockets
<b>TYRES</b>	260/70R16*300/70R20 - 260/70R16*340/65R20 - 280/70-18*360/70R20 - 280/70-18*320/70R24 - 320/65R18*380/70R20 - 340/65R18*420/65R24 - 320/65R18*320/70R24 - 280/70R18*380/70R20
<b>TOW HOOKS</b>	Standard: front and rear CUNA cat. C adjustable in height - Optional: rear tow hook EC approved or EC with Slider frame or CUNA with Slider frame or EC tow bar with Slider frame
<b>WEIGHT IN ORDER OF SPEED</b>	With roll-bar: 2520 kg - With cab: 2700 kg
<b>ADDITIONAL OPTIONS</b>	Front bumper, beacon lamp, front plate for implements connection, front weights kg 150, weights kg 50 each for 18" front wheels, cast iron flange kg 50 each for 20" rear wheels, cast iron flange kg 70 each for 24" rear wheels, silver and bordeaux 'Special Edition' livery