

CAB CAT. 4

Sky Jump K90 is available with a **COMPACT PRO cab**, pressurised and homologated for **Category 4**, insulating operators from toxic inhalation during phytosanitary treatments, for a healthy and safe working environment.

The low-profile monocoque chassis, which is fitted on the silent block to reduce noise and vibrations to the benefit of operational comfort, makes use under the foliage in pergola vineyards, canopy plantations and greenhouses extremely easy.

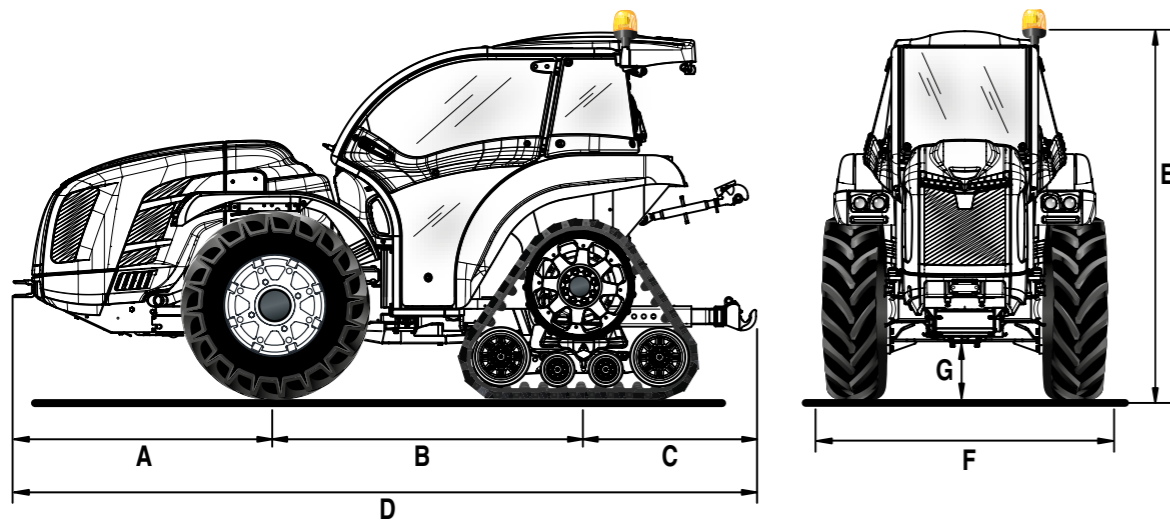

A	B	C	D	E	F	G
1348	1607	968	3923	1853	1350	254

* Dimensions in mm

TECHNICAL FEATURES	SKY JUMP K90 DUALSTEER®
ENGINE	Kubota V3800-CR-T-EW03 Diesel direct injection common rail Turbo 4 cylinders 3769 cc Liquid cooling Stage V
Power	54.6 kW / 75 hp @2400 rpm Max torque 305.4 Nm@1500 rpm
Speed management	Electronically regulated with a console with functions: increase and decrease of engine speed, memorize and recall a particular speed, switch off the electronic throttle and go to the minimum idle speed
CHASSIS	Swinging integral chassis (±15°) OS-FRAME with central articulation and steering wheels
DRIVE	Four-wheel drive. Front-wheel drive disengagement with electro-hydraulic control
TRANSMISSION	32 speeds synchronized gearbox: 16 FWD and 16 REV with synchronized reverser
Min/max travel speed (km/h)	0.7 / 40
POWER SHUTTLE EASYDRIVE® (optional)	Electronically controlled electro-hydraulic with lever positioned to the left of the steering wheel and two available reversing modes: slow reverse and quick reverse
Transmission clutch	Multidisc in oil bath electronically-managed and proportional hydraulic control with PRO-ACT System
DIFFERENTIAL	Front and rear. Differential lock: front and rear simultaneously or only rear with electro-hydraulic control
AXLES	Front with planetary reduction units and rear with bull-gear units
REAR PTO	Independent from the gearbox and synchronized with forwarding speed. Negative safety hydraulic brake to stop the PTO
PTO clutch	Multidisc in oil bath with electro-hydraulic control
PTO rotation speed (rpm)	Standard: 540/540E - Optional: 540/1000
HYDRAULIC SYSTEM	Double circuit with independent pumps and heat exchanger
Hydraulic pump flow rate of the power steering and electro-hydraulic controls (l/min)	33.1
Hydraulic pump flow rate of the lift and control valves (l/min)	27.7 (optional oversized pump with flow rate 49 l/min)
Maximum hydraulic pressure (bar)	180
REAR CONTROL VALVES	Mechanical control, standard free flow oil return
Standard	2 double acting (total 5 hydraulic outlets)
Optional	Up to a maximum of 9 hydraulic outlets
Joystick (optional)	Proportional electronic control of rear lift (and front lift if present), 1 continuous flow with adjustable flow rate and free flow oil return, 3 double acting (replacing the standard ones). Potentiometer for adjusting the hydraulic flow rate and 49 l/min oversized pump
REAR LIFT	Standard: up/down lift with two external cylinders - Optional: position and draft-controlled
Three-point hitches	Standard: normal couplings cat. 1 and 2 - Optional: fixed arms with quick-couplings cat. 1 and 2 or Quick-couplings cat. 1 and 2, L-shaped, arms adjustable in length and hooks adjustable in width
Three-point tie bar	Standard: with manual adjustment - Optional: hydraulically controlled upper link and tie rod link arm
Ball joint lifting capacity (kg)	2700
FRONT LIFT (optional)	Two-cylinder, complete with front bumper and 4 front hydraulic outlets (replicated from the rear)
Three-point hitches	Rigid with quick couplings cat. 1
Lifting capacity (kg)	800
DRIVING PLATFORM	Monodirectional with platform suspended on silent-blocks. Suspended pedals mounted on control tower
Steering wheel	Tilt adjustable
Seat	With safety belt and man-on-board sensor. Fabric seat with adjustable spring tension according to the operator's weight
SERVICE BRAKES	Oil bath discs with hydrostatic control, acting on the four wheels with automatic engagement of the 4-wheel drive. Independent manoeuvring brakes acting on the rear wheels
Parking brake	Automatic and independent Brake-Off
STEERING	Double steering system Dualsteer® with 4-cylinders. Hydrostatic steering acting on front wheels and central joint
CABIN (optional)	"Compact Pro" low-profile, pressurised and homologated cat. 4 (activated carbon filters required). Soundproof, with monocoque body mounted on silent-blocks, beacon lamp. Safety cell integrated into the structure, automotive-type instrument dashboard and air vents. Air conditioning as standard. Optional: activated carbon filters for cat. 4
DASHBOARD	Instrument panel with analogue gauges and TFT digital colour display. Warning lights and horn
ELECTRIC SYSTEM	Battery 100 Ah / 12 V - Alternator 95 A
Standard equipment	Vehicle Control Unit, full LED street lights and indicator system, front LED working lights, rear 7-pin and 3-pin sockets
FRONT TYRES	280/70R20 * 280/70R20 PneuTrac
REAR RUBBER TRACKS	Width 305 mm, length 1223 mm
TOW HOOKS	Standard: front and rear CUNA cat. C adjustable in height - Optional: rear tow hook EC approved or EC with Slider frame or CUNA with Slider frame
WEIGHT IN ORDER OF SPEED	With cab: 3000 kg
ADDITIONAL OPTIONS	Front bumper, front plate for implements connection, front weights kg 150, weights kg 50 each silver and bordeaux 'Special Edition' livery