

STELLAR K90 RS

Data Sheet

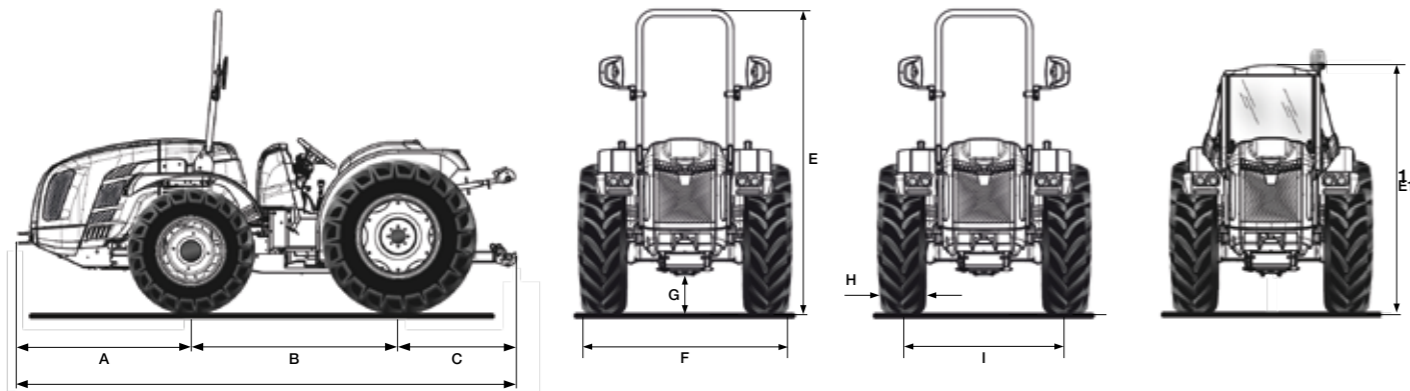

A	B	C	D	E min/max (with roll-bar)	E1 min/max (with cabin)	G min/max
1348	1607	963	3918	2195 / 2320	1700	200 / 235

* Dimensions in mm

	260/70 R16	300/70 R20	260/70 R16	340/65 R20	250/80-16	320/85 R20	280/70 R18	360/70 R20
	front	rear	front	rear	front	rear	front	rear
H	258	295	258	343	240	329	265	357
I	1122 / 1522	1054 / 1490	1122 / 1522	1054 / 1490	1122 / 1522	1054 / 1490	1098 / 1538	1170 / 1490
F	1380 / 1780	1349 / 1785	1380 / 1780	1397 / 1833	1362 / 1762	1383 / 1819	1363 / 1803	1561 / 1847

	280/70 R18	420/65 R20	250/80-18	280/85 R24 (11.2 R24)	320/65 R18	320/70 R24	320/65 R18	380/70 R20
	front	rear	front	rear	front	rear	front	rear
H	265	418	240	292	319	316	319	380
I	1098 / 1538	1204 / 1490	1098 / 1538	1030 / 1518	1166 / 1470	1130 / 1518	1166 / 1470	1204 / 1490
F	1363 / 1803	1622 / 1908	1338 / 1778	1322 / 1810	1485 / 1789	1346 / 1834	1485 / 1789	1584 / 1870

	280/70 R18	380/70 R20	280/70 R18	320/70 R24	280/70 R18	320/85 R20
	front	rear	front	rear	front	rear
H	265	380	265	316	265	329
I	1098 / 1538	1204 / 1490	1098 / 1538	1030 / 1518	1098 / 1538	1054 / 1490
F	1363 / 1803	1584 / 1870	1363 / 1803	1346 / 1834	1363 / 1803	1383 / 1819

* Dimensions in mm - min / max
H = Tyre width - I = Wheel track - F = Tractor width

TECHNICAL FEATURES	STELLAR K90 RS
ENGINE	Kubota V3800-CR-T-EW03 Diesel common rail direct injection Turbo 4 cylinders 3769 cc Liquid cooling Stage V
Power	54,6 kW / 75 hp @2400 rpm Max torque 305,4 Nm@1500 rpm
Engine speed management	Electronically regulated via hand lever and button with function for memorize and recall the set speed
CHASSIS	Swinging integral chassis (±15°) OS-FRAME with steering wheels
DRIVE	Four-wheel drive. Front-wheel drive disengagement with electro-hydraulic control
TRANSMISSION	32-speed synchronised gearbox: 16 FWD and 16 REV with synchronised reverser
Min/max travel speed (km/h)	0.7 / 40
Transmission clutch	Multidisc in oil bath with hydraulic control
DIFFERENTIAL	Front and rear. Differential lock: front and rear simultaneously or rear only with electro-hydraulic control
AXLES	Front with planetary reduction units and rear with bull-gear units
REAR PTO	Independent from the gearbox and synchronised with the forwarding speed. Negative safety hydraulic brake to stop the PTO
PTO clutch	Multidisc in oil bath with electro-hydraulic control
PTO rotation speed (rpm)	Standard: 540/540E - Optional: 540/1000
HYDRAULIC SYSTEM	Dual circuit with independent pumps and heat exchanger
Hydraulic pump flow rate of the power steering and electro-hydraulic controls (l/min)	33.1
Hydraulic pump flow rate of the lift and control valves (l/min)	27.7 (optional oversized pump with 49 l/min flow rate)
Maximum hydraulic pressure (bar)	180
REAR CONTROL VALVES	Mechanically controlled
Standard	1 double-acting with float and free flow oil return (total 3 hydraulic outlets)
Optional and in addition to the standard ones	2 double-acting (total 7 hydraulic outlets) or 1 double-acting and 1 double-acting with lockable position (total 7 hydraulic outlets)
REAR LIFT	Standard: up/down lift with two external cylinders - Optional: position and draft-controlled
3-point implement hitch	Standard: Normal couplings cat. 1 and 2. Optional: fixed arms with quick-couplings cat. 1 and 2 or L-shaped arms with quick-couplings cat. 1 and 2
Third point tie rod	Standard: with manual adjustment - Optional: hydraulically controlled upper link and tie rod link arm
Ball joint lifting capacity (kg)	2700
DRIVING POSITION	Monodirectional with footstep driving position
Steering wheel	Standard: fixed - Optional: height adjustable
Seat	Comfort seat with adjustable spring tension according to the operator's weight, safety belt and man-on-board sensor
SERVICE BRAKES	Multidisc in oil bath with mechanical control, acting on the rear wheels with automatic engagement of the 4-wheel drive. Independent manoeuvring brakes acting on the rear wheels
Parking brake	Acting on service brakes, with lever control
STEERING	Hydrostatic steering acting on the front wheels
SAFETY	Standard: front homologated roll-bar with gas springs for easy lowering and lifting
CABIN (optional)	Ultra-low profile cab (minimum height 170 cm) with monocoque chassis and platform suspended on silent-block. LED beacon lamp with foldable support, adjustable LED rear work lights, exterior mirrors and two USB sockets. Available in two versions: "Compact Clima" with air conditioning, ventilation and heating system or "Compact Pro" pressurised and Cat. 4 approved with digital pressurization control, active carbon filters as standard, USB car radio with loudspeakers and LED front work lights
DASHBOARD	Instrument panel with analogue gauges and TFT digital colour display. Warning lights and horn
ELECTRIC SYSTEM	Battery 80 Ah / 12 V - Alternator 95 A
Standard equipment	Vehicle Control Unit, street light and indicator system, front LED working lights, single-pole dashboard socket, rear 7-pin and 3-pin sockets
TYRES	260/70R16*300/70R20 - 260/70R16*340/65R20 - 250/80-16*320/85R20 - 280/70R18*360/70R20 - 280/70R18*420/65R20 - 250/80R18*280/85R24 - 320/65R18*320/70R24 - 320/65R18*380/70R20 - 280/70R18*380/70R20 - 280/70R18*320/70R24 - 280/70R18*320/85R20
TOW HOOKS	Standard: front and rear CUNA cat. C adjustable in height - Optional: rear tow hook EC approved or EC with Slider frame or CUNA with Slider frame or EC tow bar with Slider frame
RUNNING ORDER WEIGHT	With roll-bar: 2400 kg - With cabin: 2520 kg
ADDITIONAL OPTIONS	Front bumper, beacon lamp, rear adjustable working light, front weights kg 150 total, weights kg 50 each for 18" front wheels, cast iron flange kg 50 each for 20" rear wheels, cast iron flange kg 70 each for 24" rear wheels