

VEGA K90 AR

Data Sheet

MODEL YEAR 24

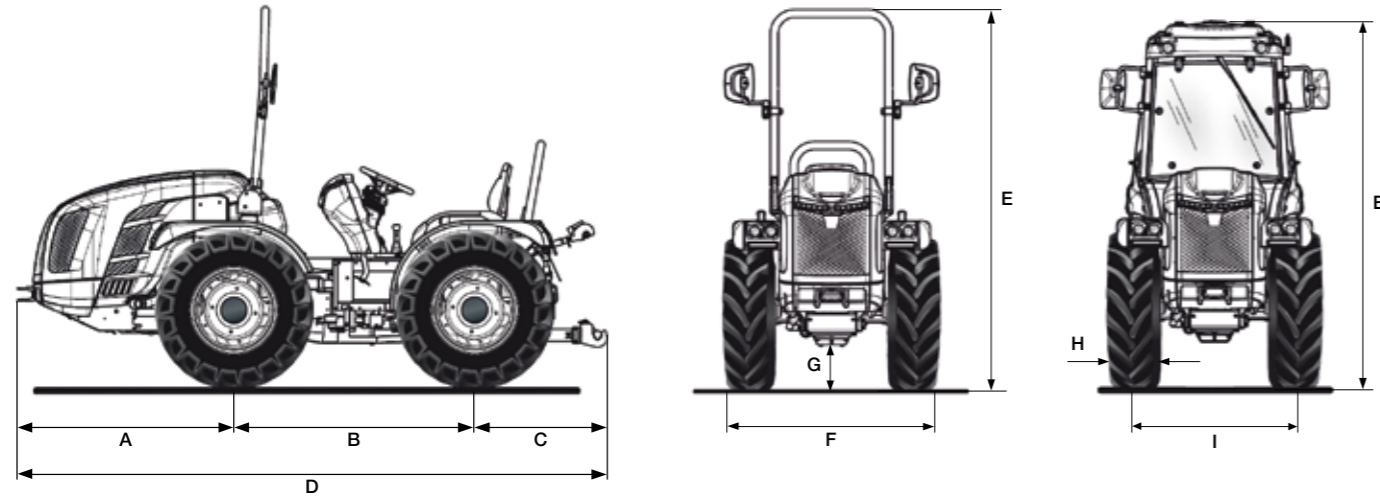

A	B	C	D	E min/max (with roll-bar)	E min/max (with cab)	F min/max	G min/max
1348	1495	932	3775	2254 / 2364	2235 / 2345	1127 / 1603	161 / 271

* Dimensions in mm

	250/80 R18	280/70 R18	280/70 R18 Garden	320/65 R18	250/85 R20	300/70 R20
	with adjustable rim	with adjustable rim	with adjustable rim	with adjustable rim	with adjustable rim	with adjustable rim
H	240	282	282	320	245	286
I	898 / 1112	1022 / 1112	1022 / 1112	1022 / 1112	882 / 1230	996 / 1260
F	1138 / 1352	1304 / 1394	1304 / 1394	1342 / 1432	1127 / 1475	1282 / 1546

	300/70 R20 Garden	340/65 R20	31x15.50-15 XTC	31x15.50-15 STG	33x12.50-15 XTC	280/70 R20 Pneu Trac
	with adjustable rim	with adjustable rim	with fixed rim	with fixed rim	with fixed rim	with adjustable rim
H	286	343	368	394	325	286
I	996 / 1260	996 / 1260	1016	1016	959 / 965	992 / 1192
F	1282 / 1546	1339 / 1603	1384	1410	1284 / 1290	1278 / 1478

* Dimensions in mm - min / max
H = Tyre width - I = Wheel track - F = Tractor width

TECHNICAL FEATURES	VEGA K90 AR - M.Y. 24
ENGINE	Kubota V3800-CR-T-EW03 Diesel common rail direct injection Turbo 4 cylinders 3769 cc Liquid cooling Stage V
Power	54,6 kW / 75 hp @2400 rpm Max torque 305,4 Nm@1500 rpm
Engine speed management	Electronic engine speed control with hand throttle control knob and push button with set speed storage/recall/exclusion function
CHASSIS	Swinging integral chassis (±15°) OS-FRAME with central articulation
DRIVE	Four-wheel drive. Front-wheel drive disengagement with electro-hydraulic control
TRANSMISSION	32-speed synchronised gearbox: 16 FWD and 16 REV with synchronised reverser
Min/max travel speed (km/h)	0.7 / 40
POWER SHUTTLE EASYDRIVE® (optional)	Electronically controlled electro-hydraulic with lever positioned to the left of the steering wheel and two available reversing modes: slow reverse and quick reverse
Transmission clutch	Multidisc in oil bath electronically-managed and proportional hydraulic control with PRO-ACT System
DIFFERENTIAL	Front and rear. Differential lock: front and rear simultaneously or rear only with electro-hydraulic control
AXLES	Front and rear with planetary reduction units
REAR PTO	Independent from the gearbox and synchronised with the forwarding speed. Negative safety hydraulic brake to stop the PTO
PTO clutch	Multidisc in oil bath with electro-hydraulic control
PTO rotation speed (rpm)	Standard: 540/540E - Optional: 540/1000
HYDRAULIC SYSTEM	Dual circuit with independent pumps and heat exchanger
Hydraulic pump flow rate of the power steering and electro-hydraulic controls (l/min)	33.1
Hydraulic pump flow rate of the lift and control valves (l/min)	27.7 (optional oversized pump with 49 l/min flow rate)
Maximum hydraulic pressure (bar)	180
REAR CONTROL VALVES	Mechanically controlled
Standard	2 double-acting and 1 double-acting with float and free flow oil return (total 7 hydraulic outlets)
Optional	With rear up/down lift: up to 12 hydraulic outlets in total - With draft-controlled rear lift: up to 9 hydraulic outlets in total
Joystick (optional)	Proportional electronic joystick with new ergonomic grip for controlling the rear lift (and front lift if present) and rear control valves consisting of: 1 continuous flow with adjustable flow rate and free flow oil return, 4 double-acting and 1 double-acting with float (control valves replacing standard ones). Additional 3/8" free flow oil return (total 13 hydraulic outlets). Potentiometer for adjusting the hydraulic flow rate and 49 l/min oversized pump. Remote PTO engagement control. Storage armrest
REAR LIFT	Standard: up/down lift with two external cylinders - Optional: position and draft-controlled
3-point implement hitch	Standard: normal couplings cat. 1 and 2 - Optional: quick-couplings cat. 1 and 2, L-shaped, arms adjustable in length and hooks adjustable in width
Third point tie rod	Standard: with manual adjustment - Optional: hydraulically controlled upper link and tie rod link arm
Ball joint lifting capacity (kg)	2300
FRONT LIFT (optional)	Two-cylinder, complete with front bumper and 4 front hydraulic outlets (replicated from the rear)
Third point arms	Rigid with quick-couplings cat. 1
Lifting capacity (kg)	800
DRIVING POSITION	Reversible with rotating platform suspended on silent blocks. Suspended pedals mounted on the rotating control tower
Steering wheel	Tilt adjustable
Seat	With gas spring for easy tipping, safety belt and man-on-board sensor. Standard: comfort seat with adjustable spring tension according to the operator's weight - Optional: 'Grammer' or 'Cobo' pneumatic seat
SERVICE BRAKES	Oil bath discs with hydrostatic control, acting on the four wheels with automatic engagement of the 4-wheel drive
Parking brake	Automatic and independent Brake-Off acting as emergency brake with proportional action
STEERING	Hydrostatic steering acting on the central joint. Flow deviator for steering unit
SAFETY	Standard: front homologated roll-bar with gas springs for easy lowering and lifting
CABIN (optional)	VISTA PRO model, pressurised and category 4 approved (activated carbon filters required). Soundproof. Four-post monocoque frame with conical profile, mounted on silent blocks. Fully glazed doors and cloth seat. A/C, ventilation and heating system. Dust filters category 2. USB bluetooth car radio with handsfree. Two USB sockets. LED work lights on the four sides of the cab (total of 10 lights). LED beacon lamp. Optional: activated carbon filters for category 4
DASHBOARD	Instrument panel with analogue gauges and TFT digital colour display. Warning lights and horn
ELECTRIC SYSTEM	Battery 100 Ah / 12 V - Alternator 95 A
Standard equipment	Vehicle Control Unit, full LED street lights and indicator system, front LED working lights, two USB sockets on the dashboard, rear 7-pin and 3-pin sockets
TYRES	250/80-18 * 280/70R18 * 280/70R18 Garden * 320/65R18 * 9.50-20 (250/85R20) * 300/70R20 * 300/70R20 Garden * 340/65R20 * 31x15.50-15 XTC * 31x15.50-15 STG * 33x12.50-15 XTC * 280/70R20 PneuTrac
TOW HOOKS	Standard: front and rear CUNA cat. C adjustable in height - Optional: rear tow hook EC approved or EC with Slider frame or CUNA with Slider frame or EC tow bar with Slider frame
RUNNING ORDER WEIGHT	With roll-bar: 2300 kg - With cabin: 2450 kg
ADDITIONAL OPTIONS	Front bumper, beacon lamp, rear adjustable working light, front weights 150 kg total and wheel weights 50 kg each, anti-bounce kit to be applied to the third point, silver and bordeaux 'Special Edition' livery