

RAPTOR 35

Data Sheet

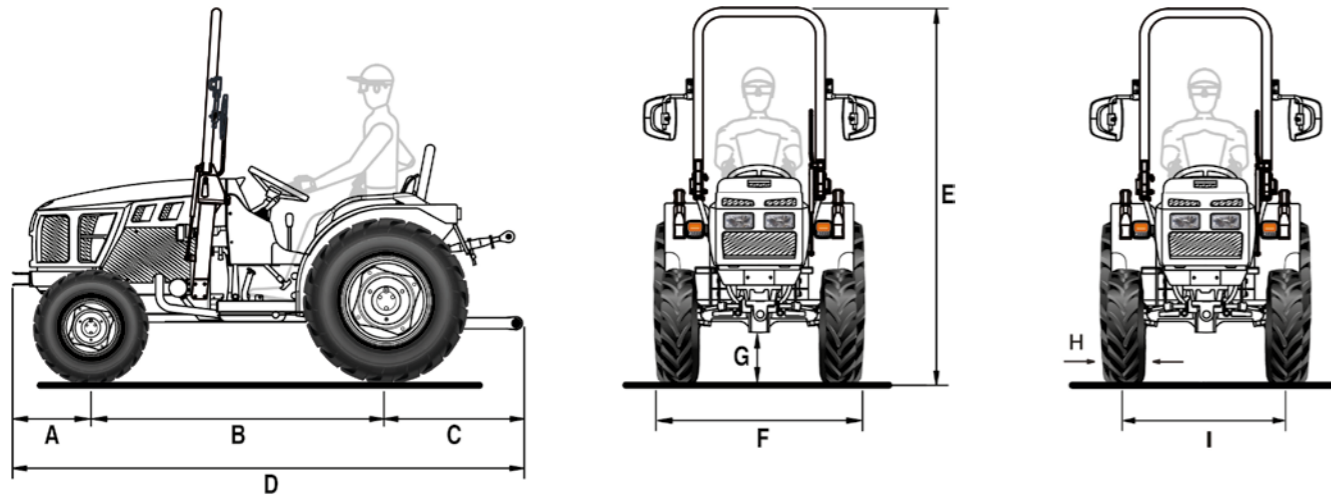

A	B	C	D	E min/max	G min/max
424	1553	730	2707	1985 / 2025	242 / 272

* Dimensions in mm

	6.5/80-12	250/80-18	23x8.50-12	280/70 R18	7.00-12	300/70 R20	25x8.50-14 Garden	380/70D-15 (36x13.50-15) Garden
	front	rear	front	rear	front	rear	front	rear
H	165	240	213	282	192	286	213	381
I	868 / 1104	881 / 1107	932 / 1044	869 / 1119	924 / 1104	873 / 1227	960 / 1016	991
F	1033 / 1269	1121 / 1347	1145 / 1257	1151 / 1401	1116 / 1296	1159 / 1513	1173 / 1229	1372

* Dimensions in mm - min / max
H = Tyre width - I = Wheel track - F = Tractor width

TECHNICAL FEATURES	RAPTOR 35
ENGINE	Kohler KDW 1404
No. of cylinders	4
Displacement (cc)	1372
Intake	Natural
Emissions compliance	Stage V
Power (kW/hp)	18.8 / 25.6
Rated speed (rpm)	3000
Max torque (Nm/rpm)	78 / 2000
Cooling	Liquid
Tank capacity (l)	26
CHASSIS	Rigid with steering wheels
DRIVE	Four-wheel drive with front-wheel drive disengagement
TRANSMISSION	24-speed synchronised gearbox: 12 FWD and 12 REV with synchronised reverser
Min/max travel speed (km/h)	0.6 / 30
Transmission clutch	Dual disc with pedal control for the gearbox - Hand lever control for the PTO
DIFFERENTIAL LOCK	Rear with mechanical control
AXLES	Front: steering, portal axle with bevel drive gear set and lateral bull-gear units - Rear: with planetary reduction units
REAR PTO	Independent from the gearbox, 540 rpm and synchronised with forwarding speed
Engagement control	Mechanical
HYDRAULIC SYSTEM	With hydraulic gear pump
Flow rate to the hydroguide, lift and control valves (l/min)	19.3
Maximum hydraulic pressure (bar)	110
REAR CONTROL VALVES	Mechanically controlled
Standard	1 double-acting (total 2 hydraulic outlets)
Optional and in addition to the standard ones	For lift by rams: 1 single-acting and 1 double-acting with float (total 5 hydraulic outlets) or 2 double-acting including 1 with or without delivery lockable position (total 6 hydraulic outlets). - For lift with draft and position control: 1 single-acting (total 3 hydraulic outlets) or 1 double-acting with lockable position (total 4 hydraulic outlets)
ELECTRIC SYSTEM	Battery: 45 Ah / 12 V - Alternator: 30 A
Rear power socket	7 pins
REAR LIFT	By two external rams. Standard: raising/lowering - Optional: position and draft control
3-point implement hitch	Normal couplings cat. 1
Third point tie rod	With manual adjustment
Ball joint lifting capacity (kg)	750
FRONT LIFT (optional)	Couplings cat. 1N, with front and under-belly PTO at 1700 rpm
Lifting capacity (kg)	350
SEAT	With safety belt and man-on-board sensor. Standard: upholstered seat, cushioned, adjustable springs and positions - Optional: 'Kab' lowered seat
SERVICE BRAKES	Rear, multidisc in oil bath
Parking brake	Acting on service brakes
STEERING	Hydrostatic steering acting on the front wheels
SAFETY	Front homologated roll-bar with gas spring for easy lowering and lifting
DASHBOARD	With instrumentation complete with fuel level indicator, engine coolant temperature, engine rpm, operating hours and warning lights
TYRES	6.5/80-12*250/80-18 - 23x8.50-12*280/70R18 - 7.00-12*300/70R20 - 25x8.50-14*380/70D-15 (36x13.50-15) Garden
TOW HOOKS (standard)	Front - Rear CUNA cat. B adjustable in height
Optional	Rear EC approved, adjustable in height
RUNNING ORDER WEIGHT with roll-bar (kg)	1100
ADDITIONAL OPTIONS	Height-adjustable steering wheel, 1700 rpm under-belly PTO, adjustable rear working light, beacon lamp, front weights 60 kg, rear wheel weights 45 kg each.