

FERRARI

M A D E I N I T A L Y



MODEL YEAR 24

NUOVA GAMMA 85 MODEL YEAR 24



VERSIONI DISPONIBILI
AVAILABLE VERSIONS
AR - RS - DUALSTEER® - MT



TRASMISSIONE
TRANSMISSION
16 + 16



POTENZA
POWER
75 hp



CAP. SOLLEVATORE POST.
REAR LIFT CAPACITY
2300 kg



POSTO DI GUIDA
DRIVING POSITION
Reversibile / Reversible

NEW RANGE 85 MODEL YEAR 24





COMFORT ASSOLUTO



Migliore ergonomia del posto guida, spazio abitativo aumentato e maggiore comfort per il conducente, sia con guida standard che retroversa!

- Maggiore corsa del sedile
- Accesso al posto guida più agevole con maggiore spazio per oltrepassare il tunnel
- Pedali in posizione più avanzata
- Tutti pedali sospesi, incluso l'acceleratore
- Nuova plancia cruscotto
- Nuovo comando dell'acceleratore manuale a pomello
- Aggiunta coppia di prese USB
- Ventola Self Cleaning System™ con portata maggiorata

ABSOLUTE COMFORT



Improved ergonomics of the driver's seat, increased living space and greater comfort for the driver, both with standard and reverse driving position!

- *Increased seat travel adjustment*
- *Easier access to the driver's seat with more space to pass over the tunnel*
- *Pedals in a more forward position*
- *All suspended pedals, including throttle*
- *New dashboard*
- *New manual throttle control with knob*
- *A pair of USB sockets has been added*
- *Self Cleaning System™ fan with increased flow*



ATTACCO ATTREZZI



- Puntone tirante 3° punto meccanico e idraulico provvisti di braccetto di fissaggio
- Protezione apribile del codolo PTO
- Nuovo tirante verticale per bracci telescopici

IMPLEMENT HITCH



- *Mechanically and hydraulically controlled upper link and third point tie rod link arm equipped with fixing arm*
- *Opening guard of the PTO tang*
- *New vertical tie rod for telescopic arms*

UPGRADE IDRAULICO



Migliorata l'offerta idraulica e la performance di raffreddamento dell'olio idraulico!

- Nuovo circuito di raffreddamento
- Aggiunto filtro spin-on in pressione su tutti gli allestimenti
- Posizionamento delle prese idrauliche posteriori sui parafanghi, anche nelle versioni RS e Dualsteer (non disponibile con cabina 'Space Klima' a 6 montanti)
- Nuova impugnatura joystick
- Distributore flottante anche con joystick
- Aggiunto un secondo Scarico Libero (3/8")
- Antidumping disponibile anche nelle versioni con joystick e sforzo controllato

HYDRAULIC UPGRADE

Improved hydraulic supply and hydraulic oil cooling performance!

- *New cooling circuit*
- *Pressure spin-on filter on all fittings has been added*
- *Positioning of the rear hydraulic outlets on the fenders, also on RS and Dualsteer versions (not available with 6-post frame 'Space Klima' cab)*
- *New joystick handle*
- *Control valve with float also with joystick*
- *A second free flow oil return (3/8") has been added*
- *Anti-dumping also available on versions with joystick and rear hydraulic lift with position and draft control*

CABINA CAT. 4



Nuova cabina conica a 4 montanti "Vista Pro"!

- Pressurizzata e omologata in categoria 4
- Fari di lavoro LED sui quattro lati della cabina per un totale di 10 LED
- Tetto in sintonia con il colore della carrozzeria
- Autoradio USB con vivavoce e diffusori acustici di serie

CAT. 4 CABIN

New conical 4-post frame cabin "Vista Pro"!

- *Pressurized and approved in Category 4*
- *LED working lights on the four sides of the cab for a total of 10 LEDs*
- *Roof in tune with body color*
- *USB car radio with speakerphone and loudspeakers as standard*

LOOK



- Fanaleria full LED con nuovi portafari
- Nuovo design del volante
- Cabina Space Klima rinnovata con montanti laterali in sintonia con il colore della carrozzeria, lampada rotante e fari posteriori LED

LOOK

- *Full LED lights with new headlights*
- *New steering wheel design*
- *Space Klima cab renewed with side pillars in tune with body color, LED beacon lamp and rear lights*

| | A | B | C | D | E | E1 | E2 | F | PESO / WEIGHT |
|----|---|---|------|------|-------------------------------|--|--|-------------|---------------------------------|
| | | | | | (con arco) (with roll-bar) | (con cabina Vista) (with Vista cab) | (con cabina Space) (with Space cab) | | (arco/cabina) (roll-bar/cab) |
| AR | | | 3500 | 3790 | 2254 / 2364 | 2138 / 2249 | | 1127 / 1603 | 2240 / 2690 |
| BR | | | 3500 | 3790 | 2254 / 2364 | 2139 / 2249 | 2070 / 2180 | 1291 / 1961 | 2390 / 2470 |
| DR | | | 3500 | 3790 | 2254 / 2364 | 2139 / 2249 | | 1291 / 1961 | 2390 / 2340 |
| FR | | | 3500 | 3790 | | | 2070 / 2180 | 1697 / 1961 | 2500 |

GAMMA 85 - MODEL YEAR 24

RANGE 85 - MODEL YEAR 24

MOTORE / ENGINE

| | | |
|--|-----------------------------|---|
| KOHLER, 4 cilindri, Turbo Common Rail <i>Kohler, 4 cylinders, Turbo Common rail</i> | |  |
| CILINDRATA <i>DISPLACEMENT</i> | 2482 cc | |
| POTENZA <i>POWER</i> | 55,4 kW / 75,3 hp @2300 rpm | |
| COPPIA MOTRICE MAX <i>MAX TORQUE</i> | 300 Nm @1500 rpm | |

DATI TECNICI / TECHNICAL DATA



| | | |
|--|---|--|
| TRASMISSIONE <i>TRANSMISSION</i> | Cambio sincronizzato 16 AV + 16 RM con frizione Easy Plus™ ⁽¹⁾ e funzione Smart Brake & Go ⁽²⁾ | <i>Synchronised gearbox 16 FWD+ 16 REV with Easy Plus™ clutch⁽¹⁾ and Smart Brake & Go⁽²⁾</i> |
| INVERSORE SINCRONIZZATO <i>SYNCHRONISED REVERSER</i> | Sì, con pulsante Power Clutch System ⁽³⁾ | <i>Yes, with Power Clutch System button⁽³⁾</i> |
| FRIZIONE <i>CLUTCH</i> | A dischi multipli in bagno d'olio a gestione elettronica | <i>Multidisc in oil bath with electronically-managed</i> |
| TELAIO <i>CHASSIS</i> | Integrale oscillante OS-Frame | <i>Swinging integral OS-FRAME</i> |
| TRAZIONE <i>DRIVE</i> | 4WD con disinserimento della trazione anteriore | <i>4WD with front-wheel drive disengagement</i> |
| PTO POSTERIORE <i>REAR PTO</i> | 540/540E rpm (540/1000 rpm su MT), indipendente e sincronizzata | <i>540/540E rpm (540/1000 rpm for MT), independent and synchronised</i> |
| IMPIANTO IDRAULICO <i>HYDRAULIC SYSTEM</i> | A doppio circuito con pompe indipendenti e scambiatore di calore, fino a 12 prese idrauliche posteriori | <i>Dual circuit with independent pumps and heat exchanger, up to 12 rear hydraulic outlets</i> |
| SOLLEVATORE POSTERIORE <i>REAR LIFT</i> | Alza e abbassa, a due cilindri esterni | <i>Raising/lowering, by two external cylinders</i> |
| CAPACITÀ SOLLEVATORE POST. <i>LIFTING CAPACITY</i> | 2300 kg (alle rotule) | <i>2300 kg (at the ball joint)</i> |
| FRENI DI SERVIZIO <i>SERVICE BRAKES</i> | A dischi in bagno d'olio con comando idrostatico, agenti sulle 4 ruote | <i>Oil bath discs with hydrostatic control, acting on the four wheels</i> |
| POSTAZIONE DI GUIDA <i>DRIVING POSITION</i> | Piattaforma rotante sospesa su silent-block e pedali sospesi | <i>Reversible with rotating platform suspended on silent blocks and suspended pedals</i> |
| CABINA <i>CABIN</i> | In opzione. 'Vista Pro' conica a 4 montanti pressurizzata e omologata Cat. 4 o 'Space Clima' a 6 montanti | <i>Optional. 'Vista Pro' 4-upright conical structure, pressurised and homologated cat. 4 or 'Space Clima' 6-upright</i> |
| PRINCIPALI OPTIONAL <i>MAIN OPTIONS</i> | Inversore elettroidraulico EasyDrive®, joystick, sollevatore anteriore, sollevatore posteriore a posizione e sforzo controllato, sospensione idraulica HDR con accumulatore, sistema anti-dumping, Self Cleaning System™, bumper anteriore, zavorre anteriori e zavorre per ruote | <i>Electro-hydraulic power shuttle EasyDrive®, joystick, front lift, rear lift with position and draft control, HDR hydraulic suspension with accumulator, anti-dumping system, Self Cleaning System™, front bumper, front weights and wheel weights</i> |

⁽¹⁾ Assistenza all'uso della frizione tramite software per innesti sempre progressivi e senza strappi.

⁽²⁾ Consente di arrestare il trattore e ripartire agendo solamente sul pedale del freno, senza usare la frizione.

⁽³⁾ Pulsante per l'innesto delle marce e dell'inversore senza l'utilizzo del pedale della frizione.

⁽¹⁾ The clutch is controlled by a software for always smooth and progressive engagements.

⁽²⁾ It allows to stop the tractor and restart by acting only on the brake pedal without using the clutch.

⁽³⁾ Button for engaging gears and reverser without using the clutch pedal.

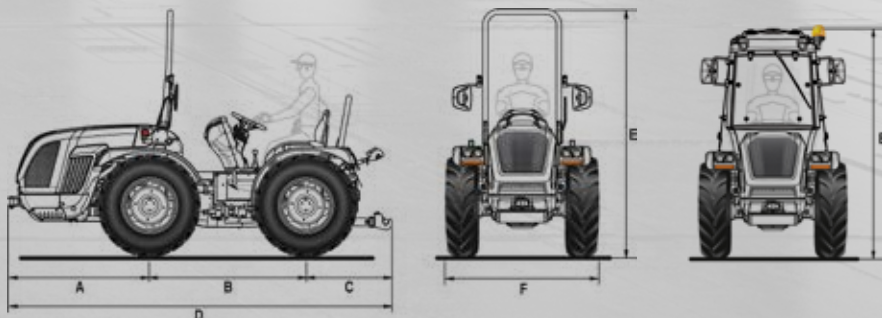

| | A | B | C | D | E (con arco) (with roll-bar) | E1 (con cabina Vista) (with Vista cab) | E2 (con cabina Space) (with Space cab) | F | PESO / WEIGHT (arco/cabina) (roll-bar/cab) |
|-----------------|------|------|-----|------|------------------------------------|--|--|-------------|--|
| AR | 1365 | 1495 | 930 | 3790 | 2254 / 2364 | 2139 / 2249 | - | 1127 / 1603 | 2240 / 2390 |
| RS | 1365 | 1495 | 930 | 3790 | 2254 / 2364 | 2139 / 2249 | 2070 / 2180 | 1291 / 1961 | 2320 / 2470 |
| DS [®] | 1365 | 1495 | 930 | 3790 | 2254 / 2364 | 2139 / 2249 | - | 1291 / 1961 | 2390 / 2540 |
| MT | 1365 | 1495 | 930 | 3790 | - | - | 2070 / 2180 | 1697 / 1961 | 2500 |

Dimensioni in mm (min / max) - Peso in kg
Dimensions in mm (min / max) - Weight in kg