

MIZAR 70 MT

Data Sheet

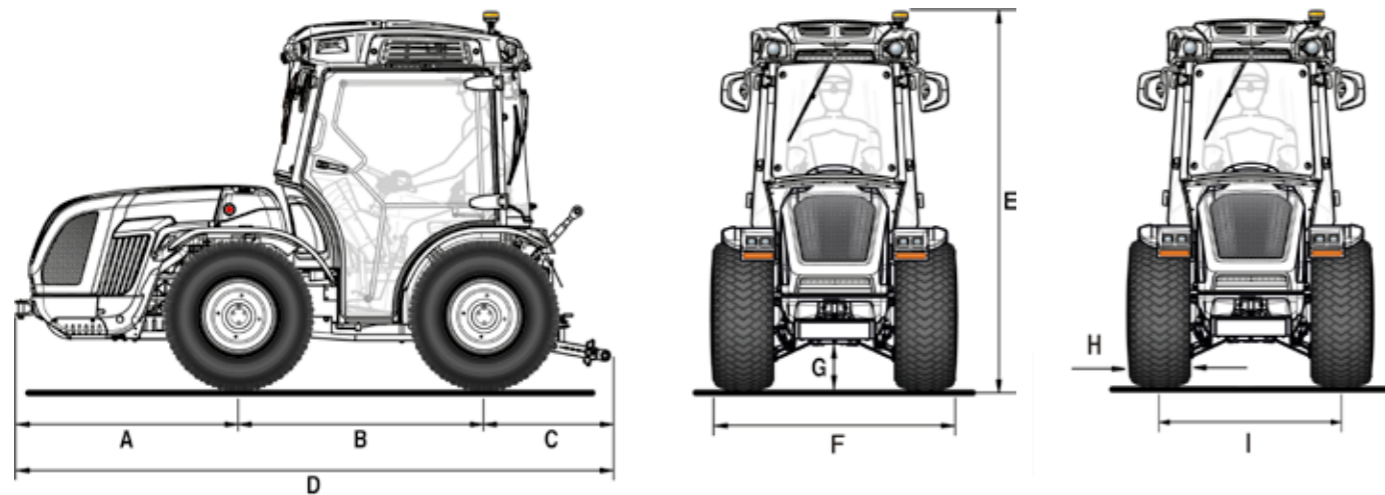

A	B	C	D	E min/max	F min/max	G min/max
1314	1480	735	3529	2145 / 2195	1684 / 1710	207 / 266

Dimensions in mm

	31x15.50-15 XTC	31x15.50-15 STG	33x15.50-15 XTC
	with fixed rim	with fixed rim	with fixed rim
H	368	394	391
I	1316	1316	1316
F	1684	1710	1707

Dimensions in mm
H = Tyre width - I = Wheel track - F = Tractor width

TECHNICAL FEATURES	MIZAR 70 MT
ENGINE	Kohler KDI 2504 TCR Diesel common rail direct injection Turbo intercooler 4 in-line cylinders 16 valves 2482 cc Liquid cooling Stage V
Power	46 kW / 63 hp @2600 rpm Max torque 205 Nm@1500 rpm
Engine speed management	Electronically regulated with hand throttle knob and button with functions for: memorize/recall/exclude the set engine speed
Self Cleaning System™	Automatic radiator and engine intake grille cleaning system to prevent overheating
CHASSIS	Swinging integral chassis (±15°) OS-FRAME with steering wheels
DRIVE	Permanent four-wheel drive
TRANSMISSION	24-speed synchronised gearbox: 12 FWD and 12 REV with synchronised reverser
Min/max travel speed (km/h)	0.7 / 35
Transmission clutch	Multidisc in oil bath with electronically-managed and proportional hydraulic control. Power Clutch System button for engaging gears and reverser without using the clutch pedal. PRO-ACT System clutch pedal with Easy Plus™ assisted engagement. Smart Brake & Go function for automatic clutch management only with the brake pedal.
DIFFERENTIAL	Front and rear with simultaneous locking and electro-hydraulic control
AXLES	Front and rear with planetary reduction units
REAR PTO	Independent from the gearbox and synchronised with forwarding speed. Negative safety hydraulic brake to stop the PTO
PTO clutch	Multidisc in oil bath with electro-hydraulic control
PTO rotation speed (rpm)	540/540E
HYDRAULIC SYSTEM	Dual circuit with independent pumps and heat exchanger
Hydraulic pump flow rate of the power steering and electro-hydraulic controls (l/min)	13
Hydraulic pump flow rate of the lift and control valves (l/min)	37 (optional circuit with increased flow rate 48 l/min)
Maximum hydraulic pressure (bar)	180
REAR CONTROL VALVES	Mechanically controlled
Standard	1 double-acting with float and free flow oil return (total 3 hydraulic outlets)
Optional and in addition to the standard ones	Up to 7 hydraulic outlets in total
REAR LIFT	Four external cylinders with Dual Floating System® hydraulic suspension
Three-point implement hitch	Standard: quick-couplings cat. 1 and 2, L-shaped, arms adjustable in length and hooks adjustable in width - Optional: quick-couplings cat. 1 (arms not adjustable in length)
Third point tie rod	Standard: with manual adjustment - Optional: hydraulically controlled upper link and tie rod link arm (only for lift with L-shaped arms cat. 1 and 2)
Ball joint lifting capacity (kg)	1900
DRIVING POSITION	Reversible with rotating platform suspended on silent blocks. Suspended pedals mounted on the rotating control tower
Steering wheel	Height adjustable
Seat	With gas spring for easy tipping, safety belt and man-on-board sensor. Standard: comfort seat with adjustable spring tension according to the operator's weight - Optional: 'Grammer' or 'Cobo' pneumatic seat
SERVICE BRAKES	Oil bath discs with hydrostatic control, acting on the rear wheels. Independent manoeuvring brakes acting on the rear wheels
Parking brake	With handle acting on service brakes
STEERING	Hydrostatic steering acting on the front wheels. Flow deviator for steering unit
SAFETY	Standard: VISTA cab, soundproofed, ROPS and FOPS homologated. Monocoque body with a 4-upright conical structure suspended on silent block. Ventilation and heating system, LED beacon lamp, fabric seat, USB car radio with speaker phone and sound diffusers, 2 USB outlets. Optional: FULL LED working lights on four sides
CABIN (optional)	VISTA PRO cab, soundproofed, ROPS and FOPS homologated, pressurised and category 4 certified. Monocoque body with a 4-upright conical structure suspended on silent block. Air-conditioning, LED beacon lamp, fabric seat, USB car radio with speaker phone and sound diffusers, 2 USB outlets. FULL LED working lights on four sides. Optional: active carbon filters for category 4
DASHBOARD	Instrument panel with analogue gauges and TFT digital colour display. Warning lights and horn
ELECTRIC SYSTEM	Battery 80 Ah / 12 V - Alternator 95 A
Standard equipment	Vehicle Control Unit, FULL LED street light and indicator system, front LED working lights, rear 7-pin for trailer and 3-pin sockets
TYRES	31x15.50-15 XTC or STG * 33x15.50-15 XTC
TOW HOOKS	Standard: front and rear CUNA cat. C adjustable in height - Optional: rear tow hook EC approved or EC with Slider frame or CUNA with Slider frame or EC tow bar with Slider frame
RUNNING ORDER WEIGHT	With cabin: 1960 kg
ADDITIONAL OPTIONS	Front bumper, front weights 110 kg. Silver and bordeaux 'Special Edition' livery